

SONOFF

MINI Extreme

User manual V1.1

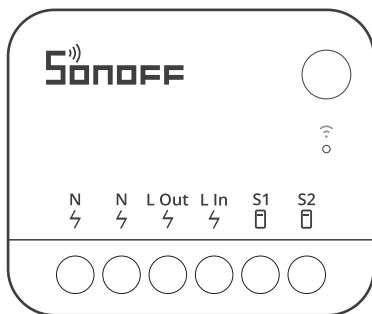

Wi-Fi Smart Switch

Product introduction

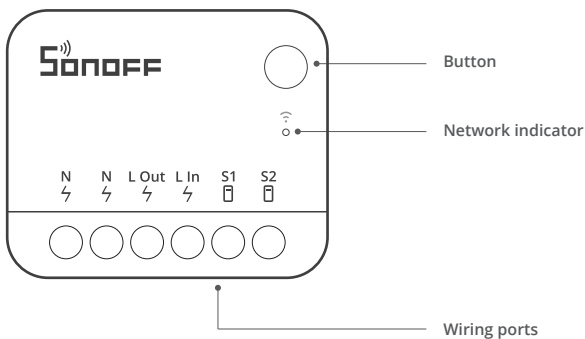

- ⚠ The device weight is less than 1kg, and the recommended installation height is less than 2m.

Instruction of LED indicator status

LED indicator status	Status instruction
Blue LED indicator flashes (one long and two short)	Pairing mode
Blue LED indicator keeps on	Device is online

Features

MINI Extreme is compact and tiny enough to be installed in the mounted box, and it supports loads of up to 10A, enable to transform your ordinary switch into a smart switch. Safe and smart, allows you to set smart scenes with other smart devices to automate your home.



Remote Control



Timer Schedule



Voice Control



LAN Control



Power-on State



Inching Mode



Smart Scene



Group Control

Installation

1. Power off

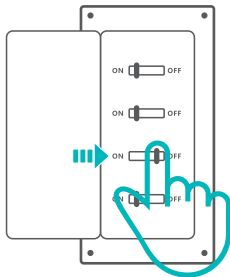

 Please install and maintain the device by a professional electrician. To avoid electric shock hazard, do not operate any connection or contact the terminal connector while the device is powered on!

2. Wiring instruction

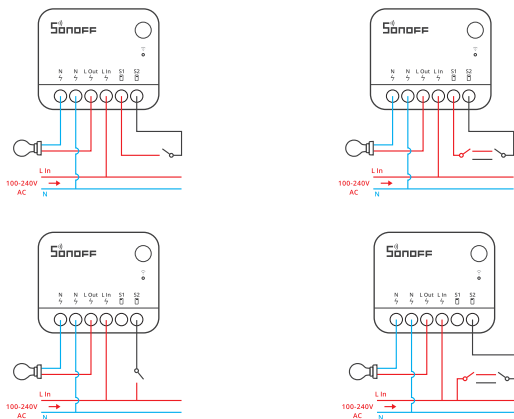

To ensure the safety of your electrical installation, it's essential either a Miniature Circuit Breaker (MCB) or a Residual Current Operated Circuit Breaker (RCBO) with an electrical rating of 10A has been installed before the MINIR4.

- 1、 No matter S1 and S2 are connected or left idle to the external switch, this device can be controlled by automation or the App.
- 2、 It is prohibited to connect S1 and S2 terminals to the neutral or ground wire, in order to avoid damaging the equipment and causing danger.
- 3、 Make sure all wires are connected correctly.

Pair with eWeLink App

1. Download the eWeLink App

Please download the "eWeLink" App from Google Play Store or Apple App Store.



2. Power on

After powering on, the device will enter the Pairing Mode defaulted during the first use, and the Network indicator flashes in a cycle of two short and one long.

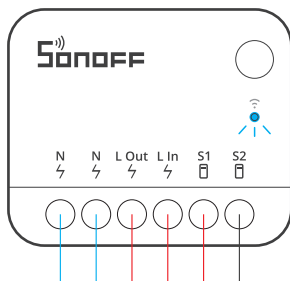

- ⓘ The device will exit the Pairing Mode if not been paired within 10mins. If you want to enter this mode again, please long press the button for 5s until the Network indicator flashes in a cycle of two short and one long and then release.

3.Add device

Open the eWeLink App, Tap "+" and select "Add Device", then operate following the prompt on the App.

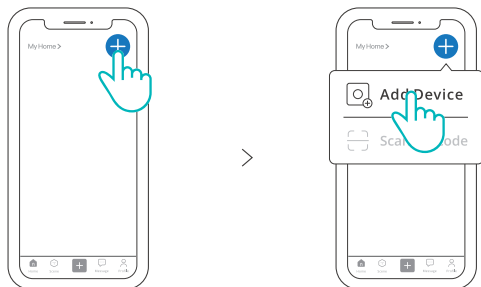

- ⓘ It's required to turn on the Bluetooth on your Phone when adding a device.

Add eWeLink-Remote Sub-devices

Enter the Device Settings page on the eWeLink App, select "eWeLink-Remote sub-devices" and tap "Add", then trigger the sub-device to add it successfully.

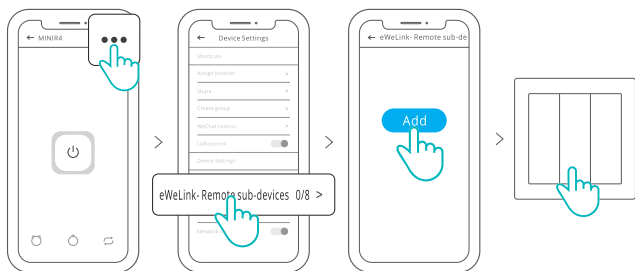

Install the MINI Extreme in the mounting box

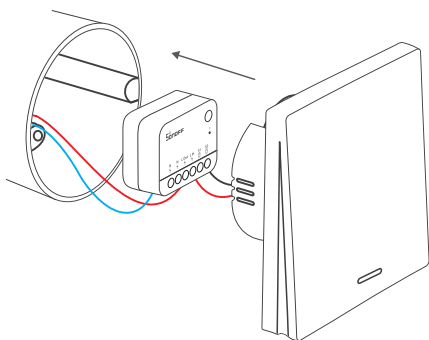

Specifications

Model	MINIR4
Input	100-240V ~ 50/60Hz 10A Max
Output	100-240V ~ 50/60Hz 10A Max
Max. power	2400W
Wi-Fi	IEEE 802.11b/g/n 2.4GHz
Working temperature	-10°C ~ 40°C
Working humidity	5%-95% RH, non-condensing
Casing material	PC V0
Dimension	39.5x33x16.8mm

Device Network Changing

Change the device's network by "Wi-Fi Settings" in the "Device Settings" page on the eWeLink App.

Factory Reset

Reset the device to factory settings by "Delete device" on the eWeLink App.

FAQ (Frequently Asked Questions)

1. Fail to pair Wi-Fi devices with the eWeLink App

1、 Make sure the device is in pairing mode.

The device will automatically exit the pairing mode if it is not paired within 10mins.

2、 Please enable location service and allow access to location permission.

Before connecting Wi-Fi network, please enable the location service and allow access to the location permission. Location information permission is used to obtain Wi-Fi list information, if you "disable" the location service, the device cannot be paired.

3. Make sure your Wi-Fi works on 2.4GHz band.
4. Make sure to enter the Wi-Fi SSID and password correctly without special characters. Incorrect password is a common cause of pairing failure.
5. To ensure good signal transmission while pairing, please place the device close to the router.

2. The LED indicator flashes twice on repeated means the server fails to connect.

1. Make sure the networking is normal. Check the internet works well by connecting your phone or PC. If fail to connect, please check the availability of the Internet connection.
2. With the low load capacity of the router, the connected devices exceed the router's maximum load capacity. Please check the maximum number of devices that your router can carry, if the connected devices exceed the maximum value, remove some devices or use a higher load capacity router.

⊙ If the above methods cannot help to solve the problem, please submit your problem to "Help & Feedback" on the eWeLink App.

3. Wi-Fi devices are "offline"

1. Devices fail to connect to the router.
2. Entered the wrong Wi-Fi SSID and password.
3. Wi-Fi SSID and password contain special characters, for example, our system can't recognize Hebrew and Arabic characters, which causes Wi-Fi connections to fail.
4. Low capacity of the router.
5. Wi-Fi signal is weak. The router and the devices are too far apart, or there is an obstacle between the router and the device, which prevents the signal from being transmitted.

FCC Compliance Statement

This device complies with part 15 of the FCC Rules. Operation is subject to the following two conditions:

- (1) This device may not cause harmful interference, and
- (2) This device must accept any interference received, including interference that may cause undesired operation.

2.Changes or modifications not expressly approved by the party responsible for compliance could void the user's authority to operate the equipment.

Note: This equipment has been tested and found to comply with the limits for a Class B digital device, pursuant to part 15 of the FCC Rules. These limits are designed to provide reasonable protection against harmful interference in a residential installation. This equipment generates, uses and can radiate radio frequency energy and, if not installed and used in accordance with the instructions, may cause harmful interference to radio communications. However, there is no guarantee that interference will not occur in a particular installation. If this equipment does cause harmful interference to radio or television reception, which can be determined by turning the equipment off and on, the user is encouraged to try to correct the interference by one or more of the following measures:

- Reorient or relocate the receiving antenna.
- Increase the separation between the equipment and receiver.
- Connect the equipment into an outlet on a circuit different from that to which the receiver is connected.
- Consult the dealer or an experienced radio/TV technician for help.

FCC Radiation Exposure statement:

This equipment complies with FCC radiation exposure limits set forth for an uncontrolled environment. This equipment should be installed and operated with minimum distance of 20 cm between the radiator and your body. This transmitter must not be co-located or operating in conjunction with any other antenna or transmitter.

ISED Notice

This device contains licence-exempt transmitter(s)/receiver(s) that comply with Innovation, Science and Economic Development Canada's licence-exempt RSS(s). Operation is subject to the following two conditions:

(1) This device may not cause interference.

(2) This device must accept any interference, including interference that may cause undesired operation of the device.

This Class B digital apparatus complies with Canadian ICES-003.

This device complies with RSS-247 of Industry Canada.

Operation is subject to the condition that this device does not cause harmful interference.

L'émetteur/récepteur exempt de licence contenu dans le présent appareil est conforme aux CNR d'Innovation, Sciences et Développement économique Canada applicables aux appareils radio exempts de licence. L'exploitation est autorisée aux deux conditions suivantes :

(1) L'appareil ne doit pas produire de brouillage;

(2) L'appareil doit accepter tout brouillage radioélectrique subi, même si le brouillage est susceptible d'en compromettre le fonctionnement.

Cet appareil numérique de la Classe B conforme à la norme NMB-003 du Canada.

Cet appareil est conforme à la norme RSS-247 d'Industrie Canada. Le fonctionnement est soumis à la condition que cet appareil ne provoque pas d'interférences nuisibles.

ISED Radiation Exposure Statement

This equipment complies with ISED radiation exposure limits set forth for an uncontrolled environment.

This equipment should be installed and operated with minimum distance of 20 cm between the radiator and your body.

This transmitter must not be co-located or operating in conjunction with any other antenna or transmitter.

Cet équipement est conforme aux limites d'exposition aux rayonnements de la ISED établies pour un environnement non contrôlé.

Cet équipement doit être installé et fonctionner à au moins 20cm de distance d'un radiateur ou de votre corps.

Cet émetteur ne doit pas être co-localisé ou fonctionner en conjonction avec une autre antenne ou un autre émetteur.

SAR Warning

Under normal use of condition, this equipment should be kept a separation distance of at least 20cm between the antenna and the body of the user.

Dans des conditions normales d'utilisation, cet équipement doit être maintenu à une distance d'au moins 20 cm entre l'antenne et le corps de l'utilisateur.

WEEE Warning



WEEE Disposal and Recycling Information All products bearing this symbol are waste electrical and electronic equipment (WEEE) as in directive 2012/19/EU which should not be mixed with unsorted household waste. Instead, you should protect human health and the environment by handing over your waste equipment to a designated collection point for the recycling of waste electrical and electronic equipment, appointed by the government or local authorities. Correct disposal and recycling will help prevent potential negative consequences to the environment and human health. Please contact the installer or local authorities for more information about the location as well as terms and conditions of such collection points.

EU Declaration of Conformity

Hereby, Shenzhen Sonoff Technologies Co., Ltd. declares that the radio equipment type MINIR4 is in compliance with Directive 2014/53/EU. The full text of the EU declaration of conformity is available at the following internet address:

<https://sonoff.tech/usermanuals>

Scatola	Manuale	Neto
PAP 21	PAP 22	EVA 7
Carta	Carta	Plastica
RACCOLTA DIFFERENZIATA		
Verifica le disposizioni del tuo Comune. Separa le componenti e conferiscile in modo corretto.		

For CE Frequency:

Operation frequency Range:

2402-2480MHz(BLE)

2412-2472MHz(Wi-Fi)

RF Output Power:

1.87dBm(BLE)

16.12dBm(802.11b),15.80dBm(802.11g),15.67dBm(802.11n20),

13.33dBm(802.11n40)(Wi-Fi)

SONOFF

Shenzhen Sonoff Technologies Co., Ltd.

3F & 6F, Bldg A, No. 663, Bulong Rd, Shenzhen, Guangdong, China

ZIP code: 518000

Website: sonoff.tech

MADE IN CHINA



FR

Cet appareil
se recycle

À DÉPOSER
EN MAGASIN



À DÉPOSER
EN DÉCHÈTERIE

OU



Points de collecte sur www.quefairedemesdechets.fr
Privilégiez la réparation ou le don de votre appareil !